



# JADE X WP1

## SETUP GUIDE



POWERED BY



Version 1.0

# **WARNING!**

**Failure to comply with these warnings and instructions may cause SERIOUS INJURY, DEATH, or DAMAGE TO YOUR PRODUCT.**

Be sure to read this manual carefully before using your DVO suspension. Throughout this manual, reference is made that “an accident” could occur. Any accident may cause damage to the product, SERIOUS INJURY, OR DEATH.

These instructions contain important information about the correct installation, guidelines for set-up, service and maintenance of your suspension. Nevertheless, please be informed that special knowledge and tools are essential to install, service and to maintain DVO Suspension. Common mechanical knowledge may not be sufficient to repair, service or maintain your suspension. Therefore we strongly recommend getting your suspension installed, serviced and/or maintained by a trained and qualified bicycle mechanic. Improper installation, service or maintenance can result in an accident.

Forks and rear shocks contain fluids and air under extreme pressure. DO NOT attempt to disassemble any portion of a DVO Suspension product unless instructed to do so by a DVO Suspension authorized technician.

Only use genuine DVO Suspension replacement parts. Modification, improper service, or the use of aftermarket replacement or spare parts may result in an accident and VOIDS the warranty of your product.

DVO Suspension forks and rear shocks are designed for the usage by a single rider only.

DO NOT use DVO Suspension products on any powered vehicle that is not a pedal-assist Class-1 or Class-3 e Bike.

Always be equipped with proper safety gear. This includes a properly fitted and fastened helmet. According to your riding style you should use additional safety protection. Make sure your equipment is in flawless condition.

Make sure you select the correct fork and rear shock according to your frame manufacturer specification. Installing suspension that does not match the geometry of your frame could result in a failure of the suspension itself and void the suspension warranty. Installing a fork or rear shock not designed for your frame will change the geometry and handling of your bike. Learn how to ride and train your skills. Know your limits and never ride beyond those.

Study all other manuals provided with your bicycle and make yourself familiar with all components mounted to your bike.

## PRE-RIDE SAFETY CHECK

1. DO NOT ride your bicycle if any one of the following test criteria is not passed! Riding your bike without eliminating any defect or carrying out the necessary adjustments can result in an accident, SERIOUS INJURY OR DEATH.
2. Do you notice any cracks, dents, bent, or tarnished parts of your suspension fork or shock, or any other part of your bicycle? If so, please contact a trained and qualified bicycle mechanic to check your fork, shock, seat post, saddle, and complete bike.
3. Do you notice any oil leaking from your fork and/or shock? If so, please consult a trained and qualified bicycle mechanic to check your suspension and bike before riding.
4. Make sure your wheel is attached and centered properly in order to avoid any contact with the suspension fork or brake system.
5. Make sure your axle system is secure. There should be no play between the hub and fork lower.
6. Make sure your brakes are properly installed, adjusted, and work properly. This also applies to every other part of your bike like handlebars, pedals, cranks arms, seat post, saddle, etc.
7. Check the cable length and routing of your braking components. Make sure they do not interfere with your steering actions or full compression and extension of your suspension.
8. Check your shock hardware and ensure there is no play between the shock and mounting surfaces. Ensure your shock hardware is tightened to the bike manufacturer's recommend torque before riding.

## Things to look for.

### Alignment

When installing your shock, it should slide in smoothly. If you have to force, bend, or twist the shock into position, something is off. If you run into this problem, double check you have the correct size shock and mounting hardware for your frame. If everything is correct, there could be an alignment issue with your frame. Consult your bike manufacturer for further help.

### Correct Stroke Length

This is a big one! It's important to make sure the stroke of the shock matches the stroke required of the bicycle. Before installing the coil spring, be sure to cycle the shock to full-travel. There should be NO frame contact points at any spot in the cycle. If at any point in the travel the shock hits the frame, tire hits the seat-tube, or any other contact happens, DO NOT ride the bicycle. Make sure you have the correct specs and contact your bicycle manufacturer.

### Smooth Movin'

With the shock mounted in the frame and the air released, make sure the linkage and shock cycle smoothly throughout the travel. If it feels notchy and inconsistent, double check torque specs and fitment specs. You may be required to contact your frame manufacturer if the problem persists.

## Shock at Full Extension

Check to make sure the shock does NOT come in contact with the frame.

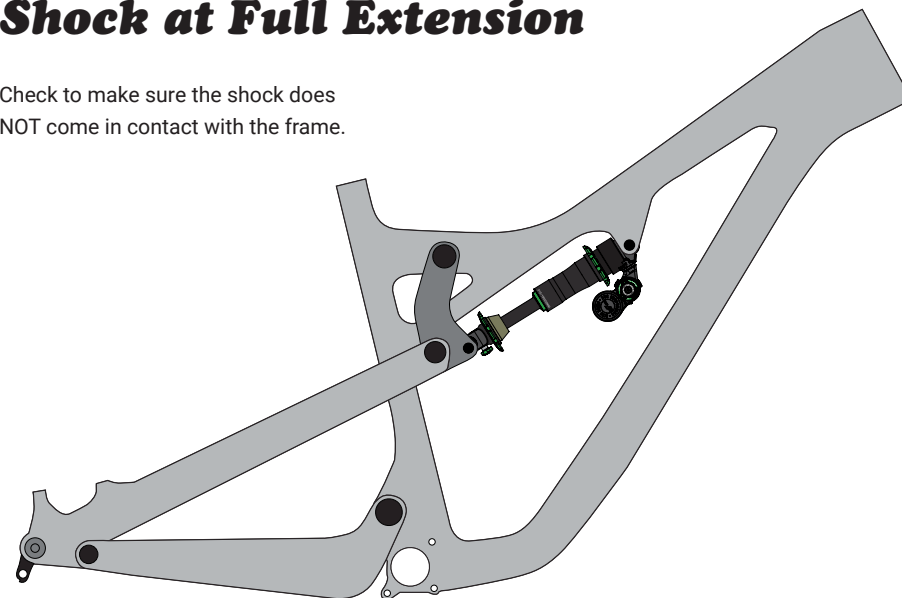

## Shock at Bottom Out

When the shock and linkage are at full compression, make sure nothing comes in contact or hits.

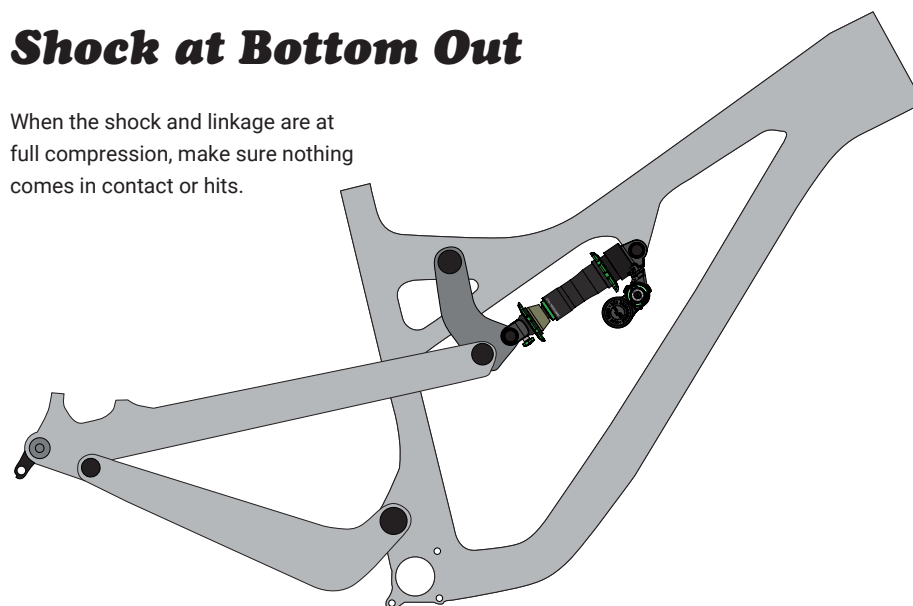

## Tools Needed For Setup

1. Shock Pump
2. Tape Measure or Calipers
3. Protective eyewear

## SOME HELPFUL TIPS

1. All of these settings are just starting points to get you close. Don't be afraid to use your adjusters or change up your settings to make it perfect for you.
2. Write down your settings! Modern suspension products have a ton of adjustment which is awesome, but you can get lost. When you find a good spot, write it down so you can always go back to it.
3. Dedicate time to setting your bike up for the trail, not the parking lot. It's a good idea to get out on the trail and find a section you can repeat. Try different settings to truly feel what the adjusters are doing. Once you truly understand what they do and feel like, you'll know when to use them in any situation.
4. Balance is key! This is a big one. Try your best to get your fork and shock feeling equal. If the rebound in the rear shock is way faster than the fork, the bike won't have a very predicable ride. Feel to make sure the rebound, spring rate, and compression are having similar feelings front and back. This will provide a predictable and confidence inspiring ride.
5. If you have questions, don't hesitate to ask. Give us a call, shoot us an email, we'll get you dialed in!



### Jade X WP1



## Bladder Adjust

The bladder is a tuning feature to tailor the feel of the shock to the rider. Try a higher or a lower pressure to find what suits you. The chart below is a starting point, feel free to try the full pressure range!



**BLADDER PRESSURE  
RANGE 140-180PSI  
DO NOT EXCEED 180PSI**

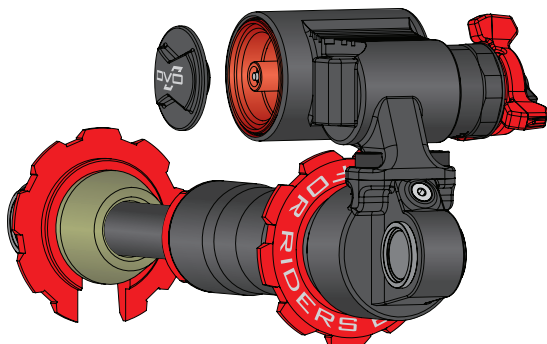

Bladder Pressure Base Setting Chart

Rider Weight		Air Pressure (psi)				
lbs	kg	140	150	160	170	180
120-139	54-63	PLUSH	FIRM			
140-159	64-72	PLUSH	FIRM			
160-179	73-81		PLUSH FIRM			
180-199	82-90		PLUSH FIRM			
200-219	91-100			PLUSH FIRM		
220-239	101-108			PLUSH FIRM		
240+	109+				PLUSH FIRM	

## What are bladders in shocks and how do they work?

Bladders are located in the reservoir of the rear shock and take the place of a traditional IFP (internal floating piston). They both have the same purpose but completely different ways of executing it. That purpose is to separate the air from the oil. A bladder is basically a balloon which is filled with air and seated to the end cap. The bladder is charged with a high PSI to push back against the oil which creates pressure in the system. As the shock is compressed, oil flows through the system and starts to compress the bladder.

## Setting SAG

### What is SAG?

SAG is the amount the shock compresses under your own body weight. Make sure you check your SAG with all your riding gear on (riding shoes, hydration pack, etc).

The recommended SAG is 25% - 30%. Setting proper SAG is the only way to find the right spring rate for your shock/body weight. Refer to the chart below to find the proper SAG.

Stroke	25% SAG (mm's)	30% SAG (mm's)
60mm	15	18
65mm	16.25	19.5

### Can SAG effect the handling of my bike?

It is very beneficial to experiment with different SAG settings for various riding styles and suspension kinematics.

Less SAG equates to a firmer, more supportive ride, which sits higher up in the travel, but loses some small bump sensitivity and traction.

More SAG offers a plusher ride with less support and sits slightly deeper into the travel, but may bottom out easier.

Experiment to find the best setting that delivers a balanced ride that allows your suspension to do what it's intended to do; provide increased traction, control, and comfort!

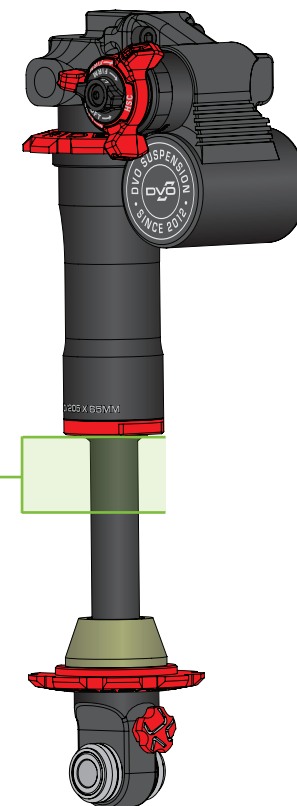

# Adjusting Preload

Adjusting your preload is a quick way to make slight increases or decreases to your SAG.

Rotating the coil spring clockwise will decrease your SAG, rotating the coil spring counter clockwise will increase your SAG.

To make preload adjustments, rotate the upper spring collar (1.) to the desired direction until the achieved amount of preload is met. Make sure there is enough tension on the spring so it is not loose or rattling.

One (1) rotation equals 1mm of preload. Do NOT exceed 6mm of preload. If you cannot achieve your desired SAG setting with the supplied spring, you may need to change to a lighter or heavier spring rate.

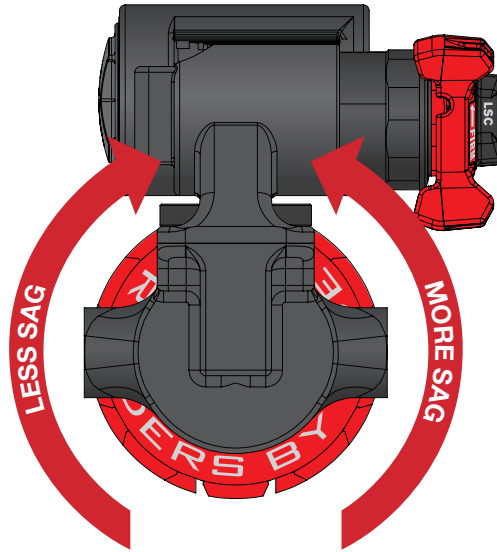

Spring Force Base Setting Chart

Rider Weight		Spring Rate	
lbs.	kg	lbs/inch	kg/cm
119-132	54-60	300	54
132-154	60-70	350	63
154-176	70-80	400	72
176-220	80-100	450	80
220+	100+	500	88



**MORE SAG - MORE PLUSH**  
**LESS SAG - MORE SUPPORT**

# Adjusting Compression

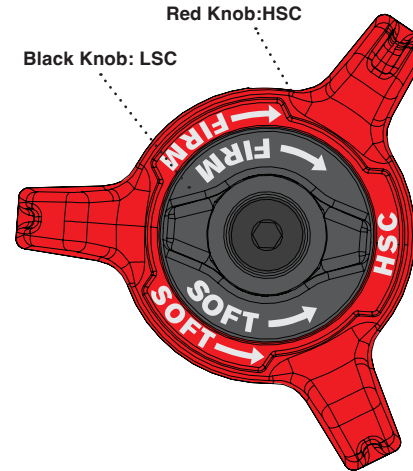

## High speed compression

Jade X WP1 products come with a full range high speed compression adjustment. This is the red knob located behind the black low speed knob. HSC controls the damping force under faster suspension movements. Use this to control the amount of support on bigger impacts such as g-outs, landings, drops, etc.

HSC Clicks (starting from closed, fully clockwise)



## Low speed compression

Jade X WP1 level products feature an adjustable low speed compression. Rotate the black LSC knob counter-clockwise until it stops; this is fully open. Rotating the LSC knob clockwise provides a firmer level of support.

Too much LSC will cause the suspension to sit too high in its travel, creating harshness and reducing traction. Experiment to find the right level of support for your riding style and trail conditions.

LSC Clicks (starting from closed, fully clockwise)

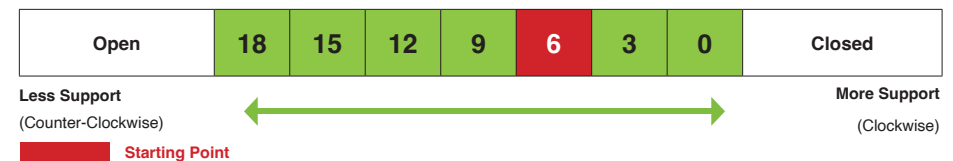

# Rebound Adjust

# Tuning Notes



## What is Rebound?

Rebound controls the speed at which the shock extends after compression. Rebound damping control is relative to the coil spring weight.

Higher spring rates requires more rebound damping. Lower spring rates will require less rebound damping so please adjust accordingly.

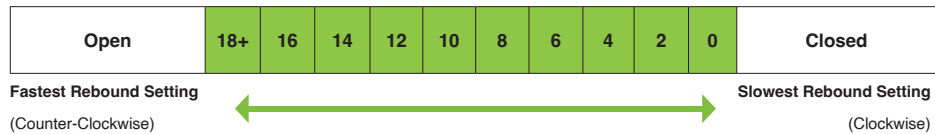

**Tech Tip!**

Rebound settings will vary greatly on bike design, trail conditions, and rider preference. It's best to start with the rebound adjuster in the closed setting (full clockwise) and adjust out in two-click increments..

---

---

---

---

---

---

---

---

---

---

---

---

---

---

---

---

---

---

---

---

---

---

---